

XOOTUBE

MONTAGEANLEITUNG INSTALLATION INSTRUCTIONS

PENDEL HORIZONTAL Stromversorgung über Kabel | PENDANT HORIZONTAL Power supply by cable

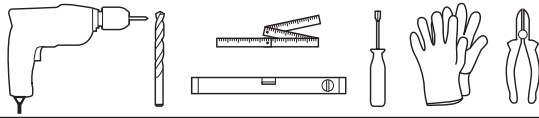

Erforderliches Werkzeug
 Required tools

Enthaltenes Zubehör
 included accessories

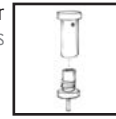

Optionales Zubehör
 Optional accessories

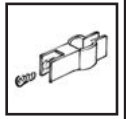

PENDEL HORIZONTAL Stromversorgung über Abpendelung | PENDANT HORIZONTAL Low voltage pendants

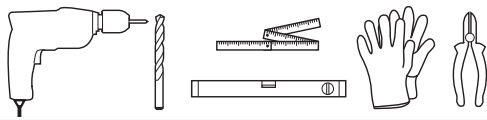

Erforderliches Werkzeug
 Required tools

Enthaltenes Zubehör
 included accessories



PENDEL VERTIKAL | VERTICAL PENDANT

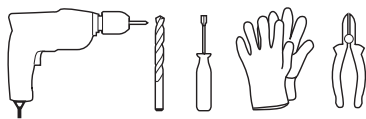

Erforderliches Werkzeug
 Required tools

Enthaltenes Zubehör
 included accessories

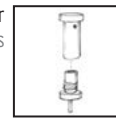

Optionales Zubehör
 Optional accessories

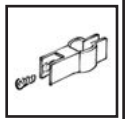

WANDMONTAGE TROCKENBAUWAND | WALL MOUNT DRYWALL

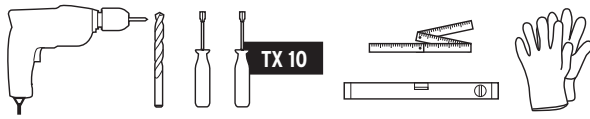

Erforderliches Werkzeug
 Required tools



XOOTUBE

MONTAGEANLEITUNG

INSTALLATION INSTRUCTIONS

Allgemeine Sicherheitshinweise

- Lesen Sie die Anleitung vor Montage und Inbetriebnahme.
- Übergeben Sie die Anleitung dem Kunden zur Aufbewahrung.
- Entfernen Sie nicht das Typenschild der Leuchte.
- Beachten Sie die nationalen Installations- und Unfallverhütungsvorschriften bei der Montage.
- Die Installation sowie der Austausch von Leuchtmitteln und Leitungen darf nur von einer geschulten elektrotechnischen Fachkraft, dem Hersteller oder einem vom Hersteller beauftragten Servicetechniker durchgeführt werden.
- Bei unsachgemäßer Montage oder nachträglicher Änderung an der Leuchte wird keine Haftung übernommen.
- Reinigen Sie die Leuchte regelmäßig mit einem angefeuchteten weichen Tuch. Benutzen Sie nur lösungsmittelfreie Reinigungsmittel. Achtung: Vorher Netzversorgung trennen und System abkühlen lassen.
- Zum Schutz der Oberflächen vor Schmutz und Fingerabdrücken empfehlen wir das Tragen von Schutzhandschuhen während der Montage.
- Die Entsorgung des Systems muss über die Entsorgung von Elektronikprodukten erfolgen gemäß der EU-Richtlinie-WEEE (Waste Electrical and Electronic Equipment).
- Zur Beantwortung von technischen Rückfragen steht Ihnen unser Kundendienst bzw. unsere weltweiten Niederlassungen und Distributoren zur Verfügung. Bitte richten Sie Ihre Anfrage an info@led-linear.com.

Anschluss

- Überprüfen Sie die Spannungsfreiheit des Systems vor Montage und Wartung. Achtung Stromschlaggefahr!
- Setzen Sie nur für die Produkte qualifizierte Dimmer und Konverter mit geeigneter Netzspannung ein. Nicht geeignete Komponenten können das Gesamtsystem beschädigen. Geeignete Produkte finden Sie in unserem Sortiment.
- Zum Anschluss der Leuchte an das Versorgungsnetz sind Anschlussklemmen in Übereinstimmung mit EN 60998-2-1 oder EN 60998-2-2 zu verwenden.
- Falsch angeschlossene Leitungen können zu einer Beschädigung der Leuchte führen.
- Verbinden und Trennen der Leuchte und des Betriebsgeräts unter anliegender Netzspannung kann zu Beschädigungen der Komponenten führen.
- Der Betrieb der Leuchte mit veränderten oder beschädigten Anschlussleitungen ist nicht zulässig.
- Stromgetriebene (Constant Current) LED-Module dürfen sekundärseitig nicht geschaltet werden.
- Schützen Sie die elektronischen Betriebsgeräte vor Überspannung.

Umgebung

- Achten Sie auf die bestimmungsgemäßen Umgebungsbedingungen, unter denen die Leuchte laut definierten Temperaturen (Ta/Tc max.) und IP-Klassifizierung betrieben werden darf.
- Achten Sie bei Deckenbefestigung der Leuchte auf die zulässigen Deckenlasten.

General Safety Instructions

- Read the instructions for installation and commissioning.
- Pass the instructions to the customer for safekeeping.
- Do not remove the type plate of the luminaire.
- The installation as well as the replacement of light source and cables may only be performed by a trained electrotechnical specialist, the manufacturer or a service technician authorized by the manufacturer.
- Please note the national installation and accident prevention regulations during installation.
- For improper installation or any subsequent change to the luminaire no liability is accepted.
- Clean the luminaire regularly with a smooth damp cloth. Only use solvent-free cleaning agents. Attention: previously cut off the mains supply and allow system to cool down.
- To protect the surface from dirt and fingerprints, we recommend the use of protective gloves during installation.
- The disposal of the system must be carried out on the disposal of electronic products in accordance with the EU Directive WEEE (Waste Electrical and Electronic Equipment).
- In order to answer technical queries, please contact our customer service respectively our worldwide branches and distributors. Please send your request to info@led-linear.com.

Connection

- Check that there is no voltage of the system prior to installation and maintenance. Beware of electric shock!
- Only suitable dimmers and converters of the correct voltage must be used. Not suitable components can damage the whole system. You will find suitable products in our range.
- Terminals in accordance with EN 60998-2-1 or EN 60998-2-2 must be used for connecting the lamp to the power grid.
- Incorrectly connected cables can cause damage to the luminaire.
- Connecting and disconnecting the luminaire and the control gear under present voltage can cause damage to the components.
- It is not allowed to use the luminaires with altered or damaged connector cables.
- Electrically operated (Constant Current) LED modules must not be secondary side connected.
- Protect the electronic operating devices from overvoltage.

Environment

- Pay attention to the allowable ambient conditions under which the luminaire may be operated according to defined temperatures (Ta/Tc max.) and IP classification.
- Pay attention to the permissible ceiling loads in case of ceiling mounting of the luminaire.



PENDEL HORIZONTAL 1.1–1.12 + 2.1–2.12

PENDANT HORIZONTAL

Stromversorgung über Kabel
Power supply by cable

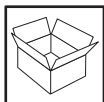

⊕ ROT | RED
⊖ SCHWARZ | BLACK

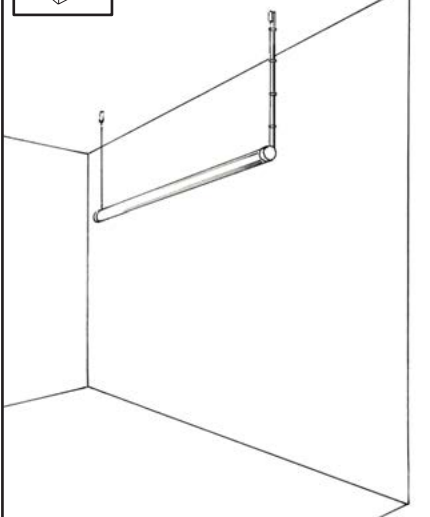

A

B

Optionales Zubehör
Optional accessories

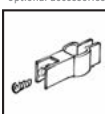
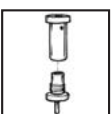

PENDEL HORIZONTAL 3.1–3.11

PENDANT HORIZONTAL

Stromversorgung über Abpendelung
Low voltage pendants

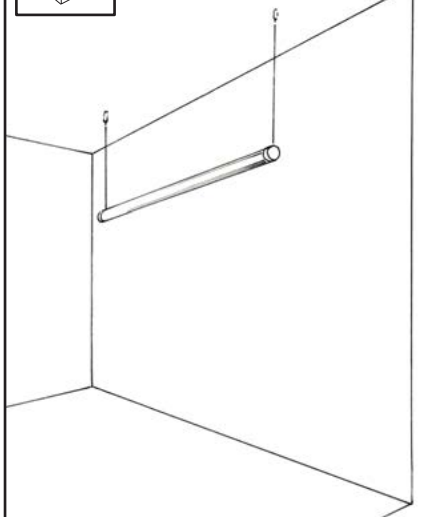
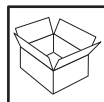

A

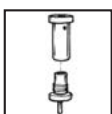

PENDEL VERTIKAL 4.1–4.8 + 5.1–5.8

VERTICAL PENDANT

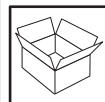

⊕ ROT | RED
⊖ SCHWARZ | BLACK

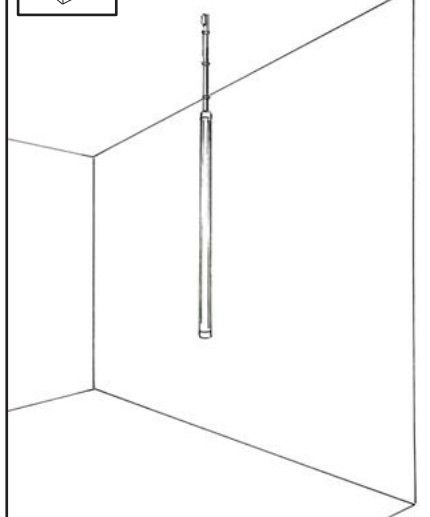

A

B

Optionales Zubehör
Optional accessories

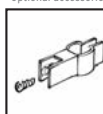

CLIPMONTAGE KABEL 6.1–6.6

CLIP MOUNTING CABLE

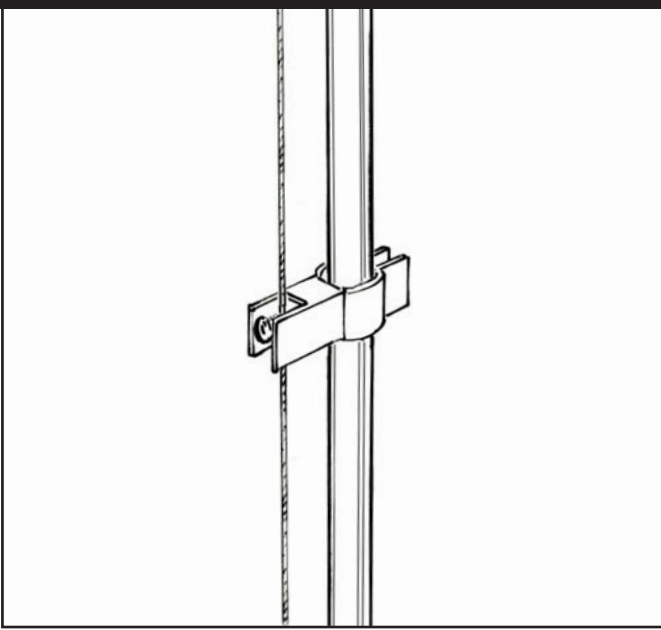

B

Optionales Zubehör
Optional accessories

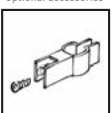

WANDMONTAGE TROCKENBAUWAND 7.1–7.11

WALL MOUNT DRYWALL

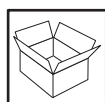

⊕ ROT | RED
⊖ SCHWARZ | BLACK

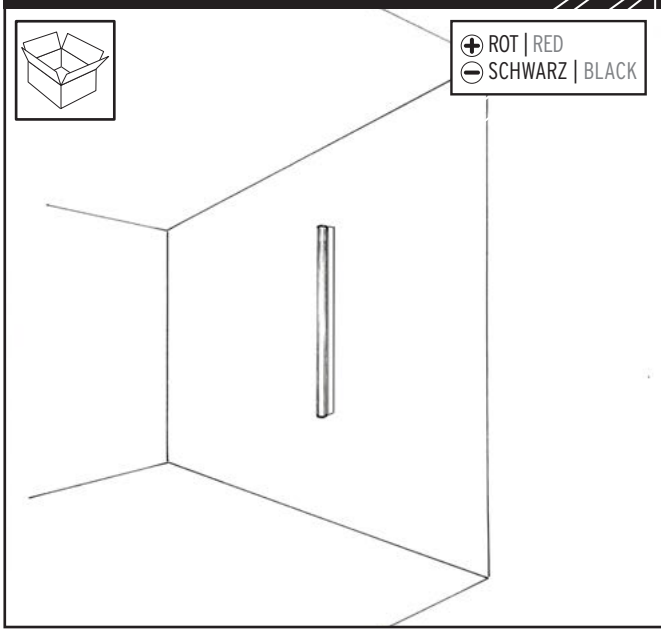

1.1

Kapitel 1 Pendel horizontal - Betondecke
Chapter 1 Pendant horizontal - Concrete ceiling

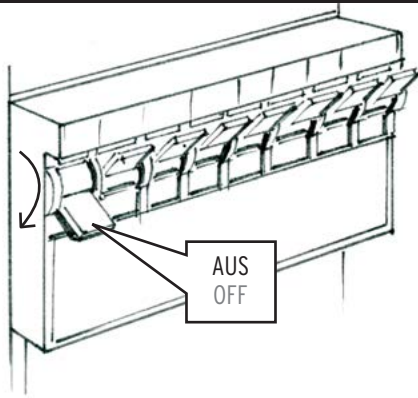

1.2

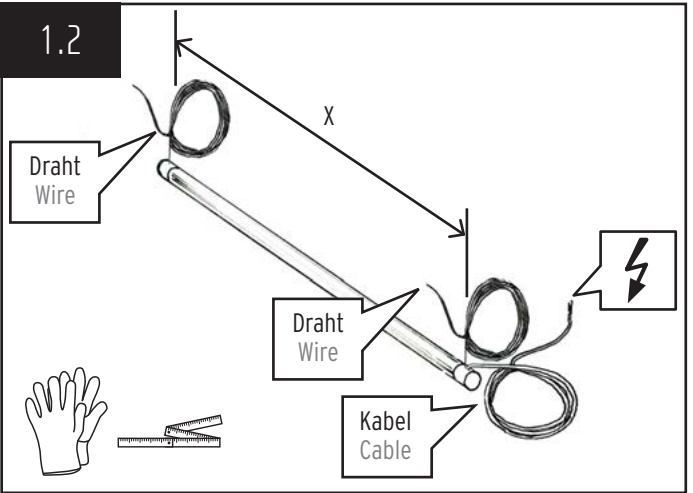

1.3

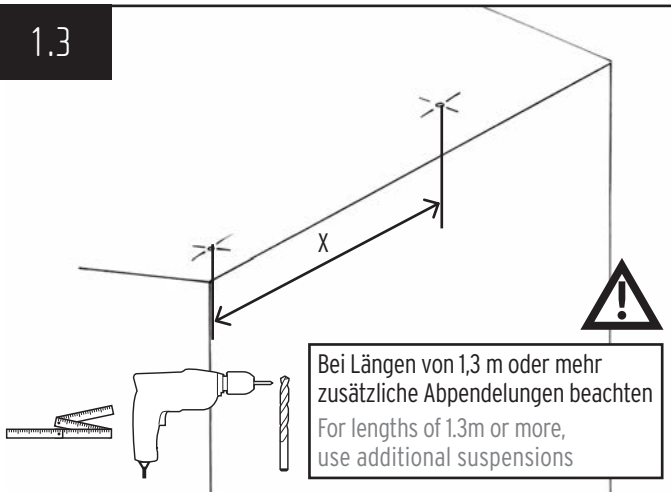

1.4

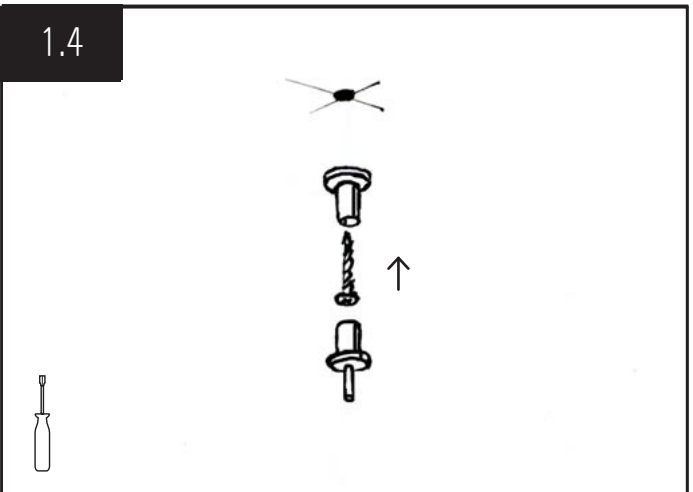

1.5

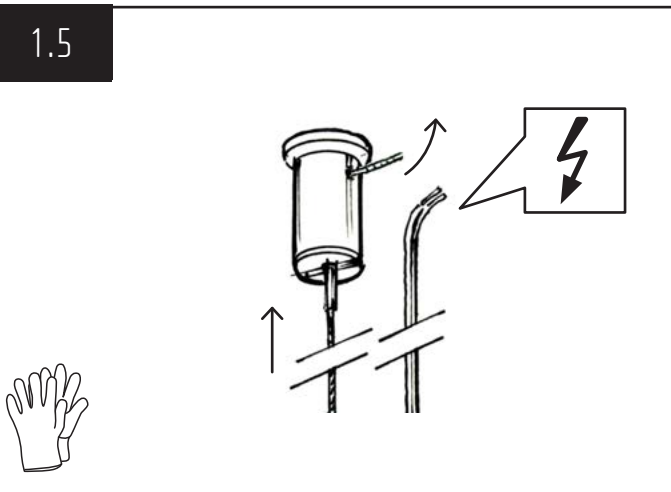

1.6

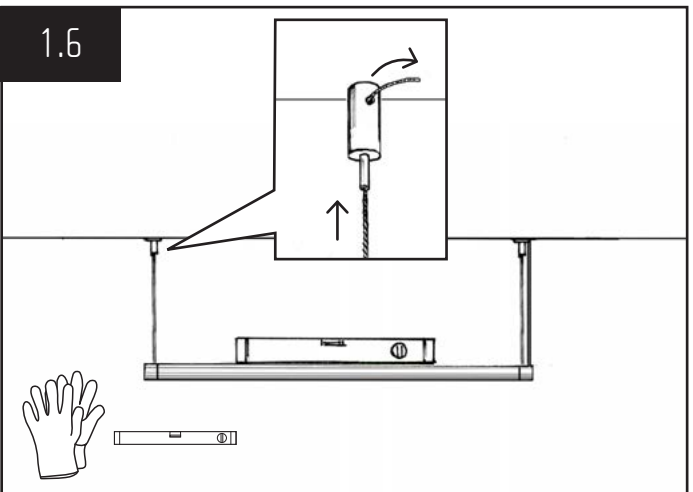

1.7

Für Leuchten mit mehr als 2 Abpendelungen
For luminaires with more than 2 pendants

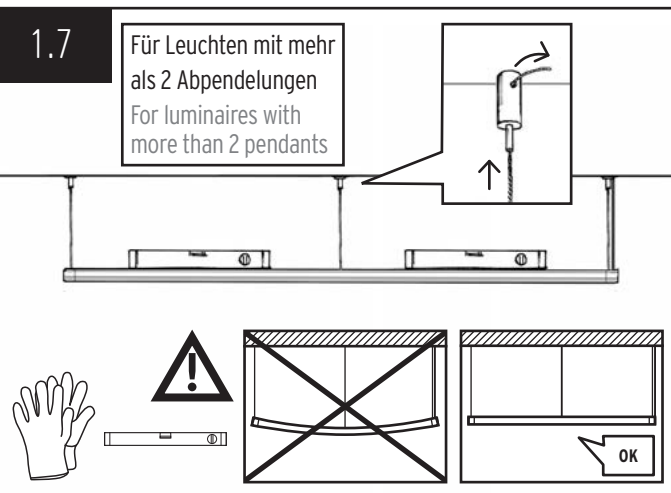

1.8

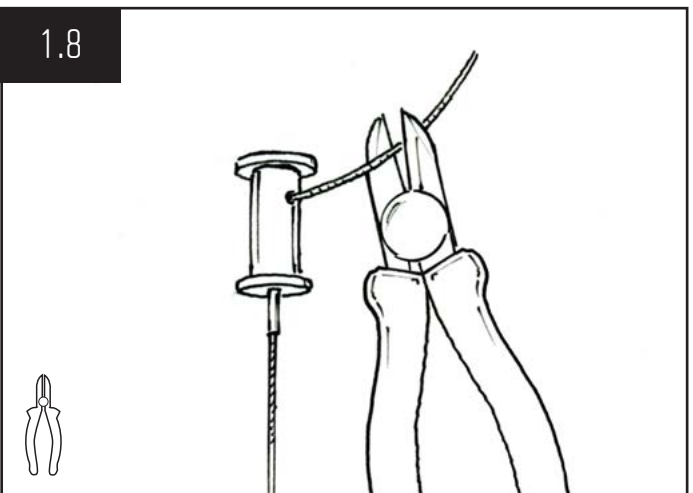

1.9

Optionales Zubehör
Optional accessories

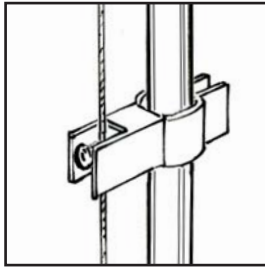

Clipmontage/Kabel: siehe Kapitel 6.1-6.6
Clip mounting/cable: see chapter 6.1-6.6

1.10

SEPARAT ERHÄLTlich
SEPARATELY AVAILABLE

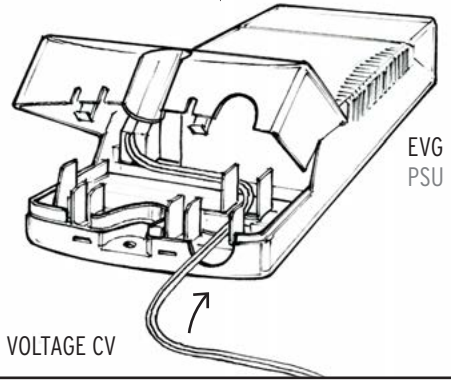

CONSTANT VOLTAGE CV

1.11

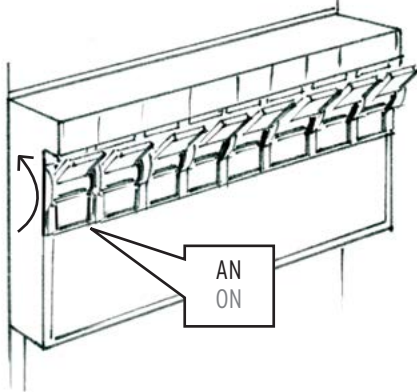

AN
ON

1.12

Siehe Montageanleitung
Baldachin (16000347)
See mounting instructions
of Square Canopy (16000347)



OK

Baldachin ist nicht Bestandteil des Lieferumfangs
Canopy is not part of the scope of delivery

2.1

Kapitel 2 Pendel horizontal - Abgehängte Decke
Chapter 2 Pendant horizontal - False ceiling

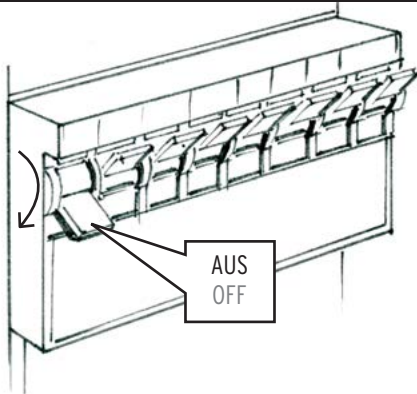

AUS
OFF

2.2

Draht
Wire



Draht
Wire

Kabel
Cable

X



2.3

Bohrloch für Kabel
Drill hole for cable

Min. 15 mm
Min. 0,59"

X

Ø 12

2.4

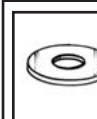

Empfohlenes Zubehör
Recommended accessories
Innendurchmesser 12 mm
Inner diameter 12 mm

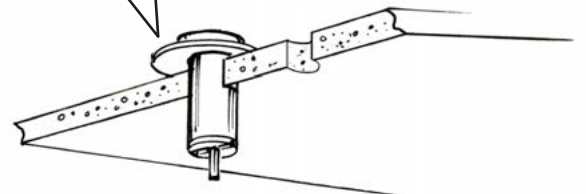
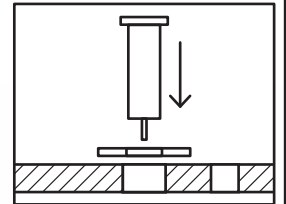

2.5

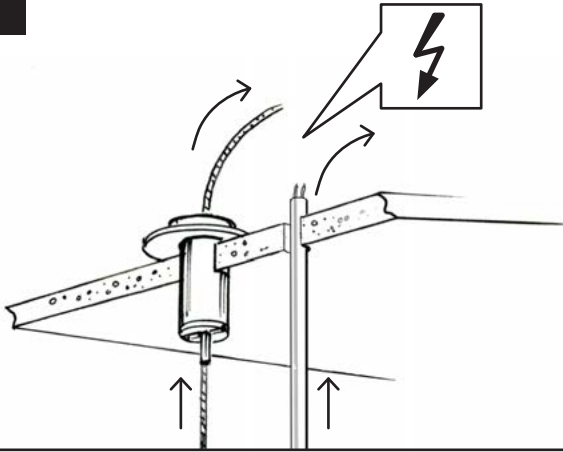

2.6

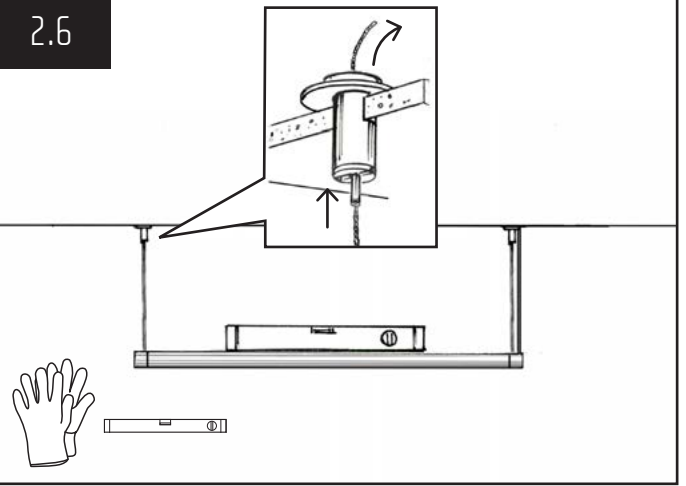

2.7

Für Leuchten mit mehr
als 2 Abpendelungen
For luminaires with
more than 2 pendants

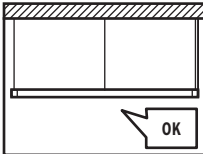
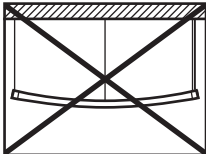
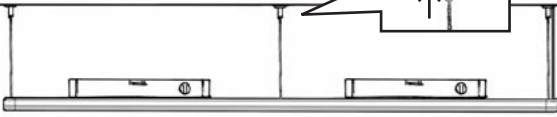
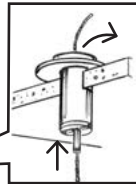

2.8

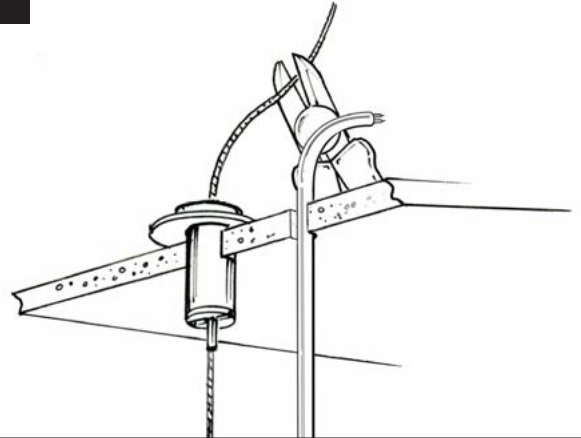

2.9

Optionales Zubehör
Optional accessories

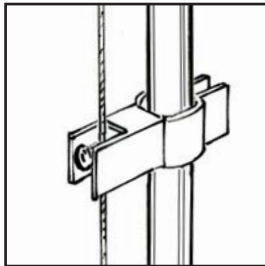

Clipmontage/Kabel: siehe Kapitel 6.1-6.6
Clip mounting/cable: see chapter 6.1-6.6

2.10

SEPARAT ERHÄLTlich
SEPARATELY AVAILABLE

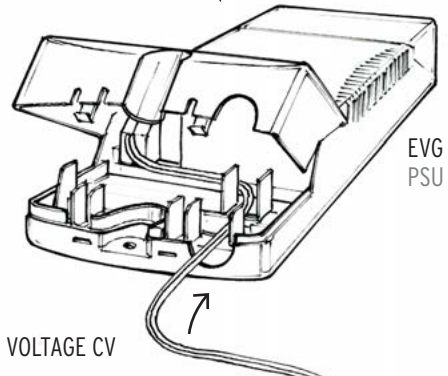

CONSTANT VOLTAGE CV

EVG
PSU

2.11

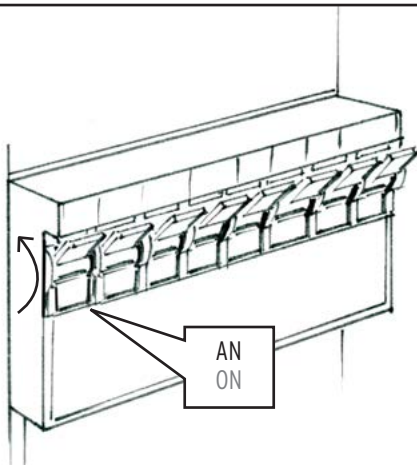

2.12

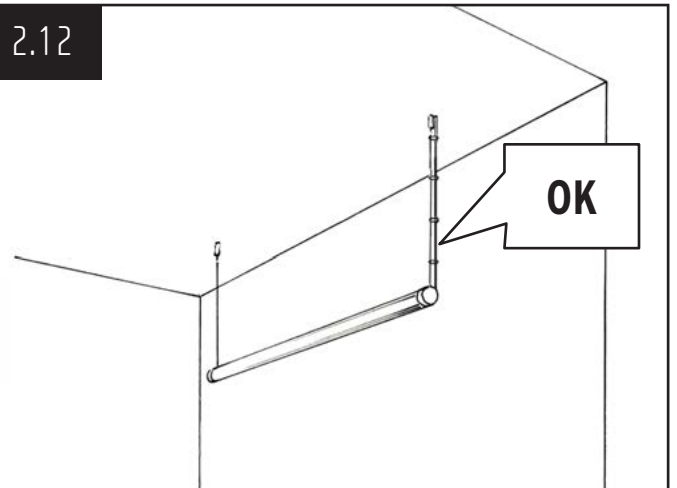

OK

3.1

Kapitel 3 Pendel horizontal - Abgehängte Decke
Chapter 3 Pendant horizontal - False ceiling

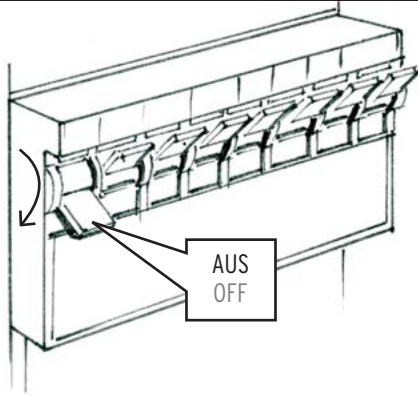

3.2

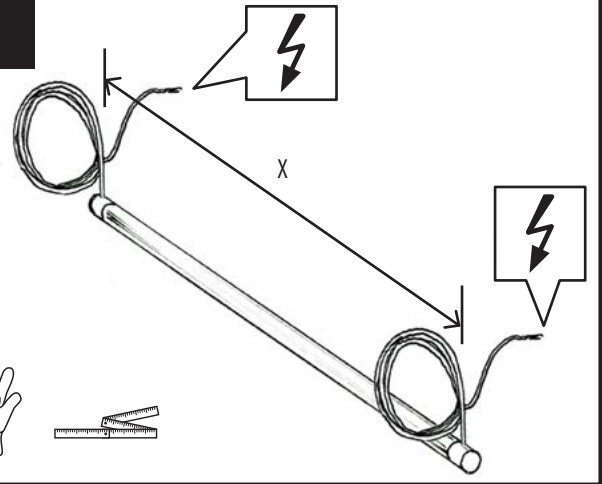

3.3

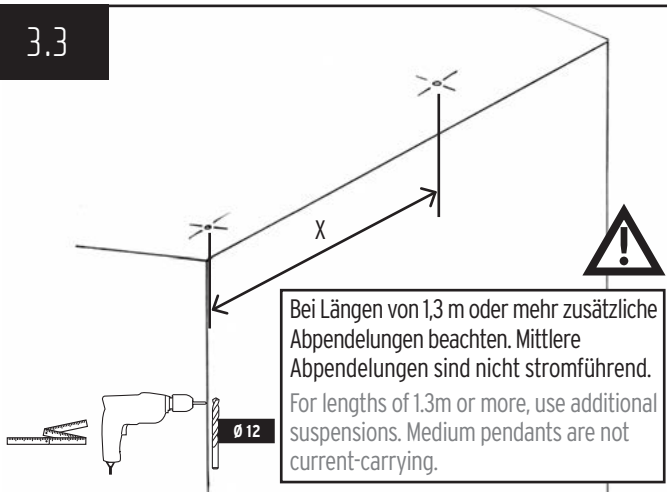

3.4

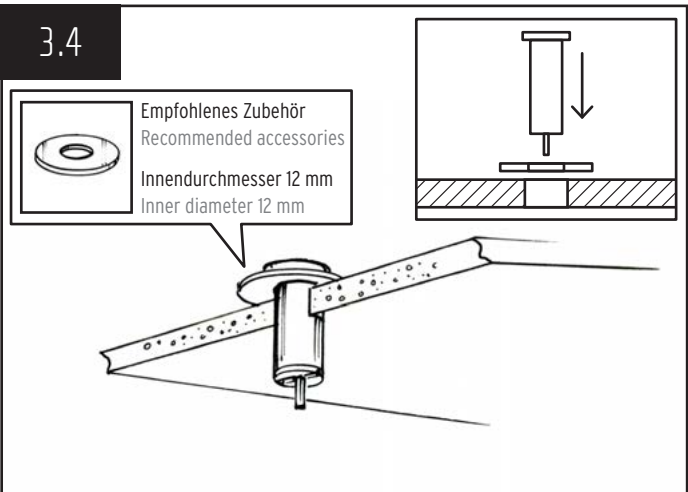

3.5

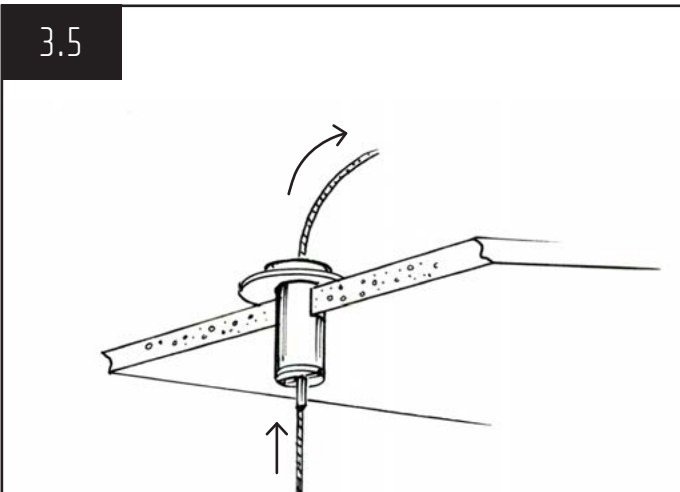

3.6

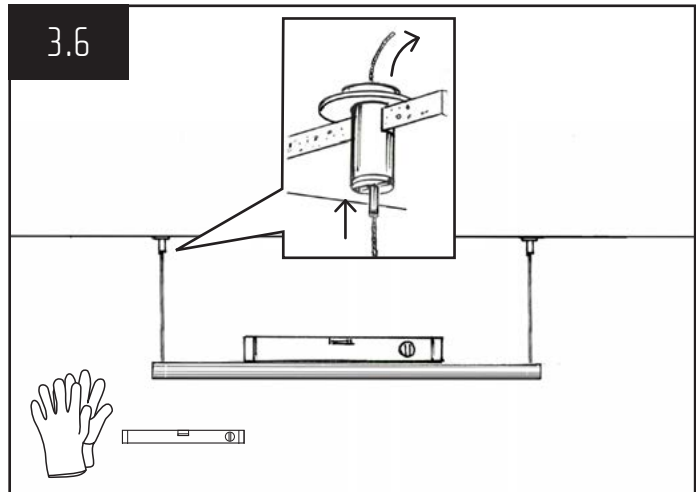

3.7

Für Leuchten mit mehr als 2 Abpendelungen
For luminaires with more than 2 pendants

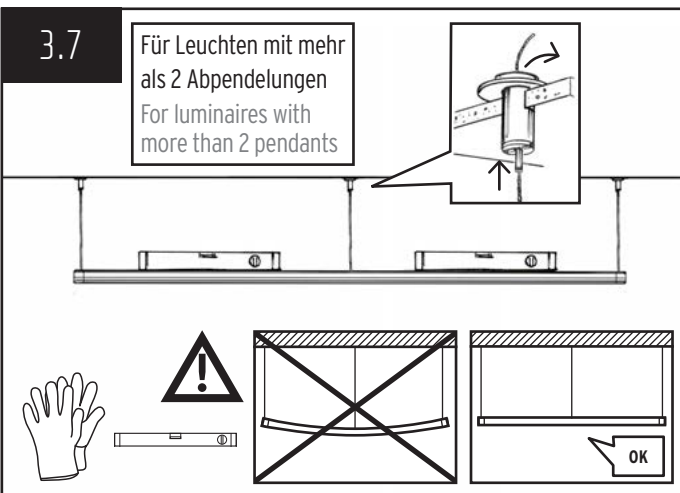

3.8

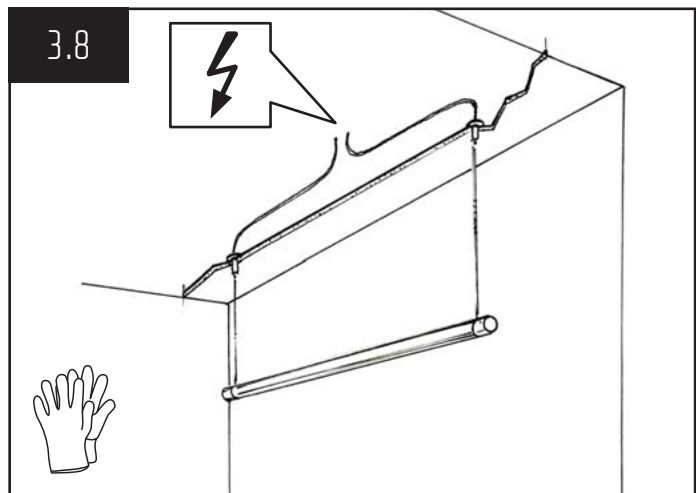

3.9

SEPARAT ERHÄLTICH
SEPARATELY AVAILABLE

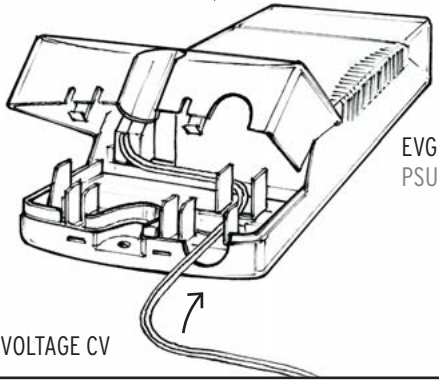

3.10

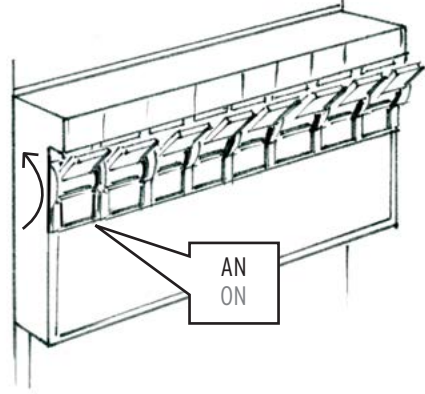

3.11

OK

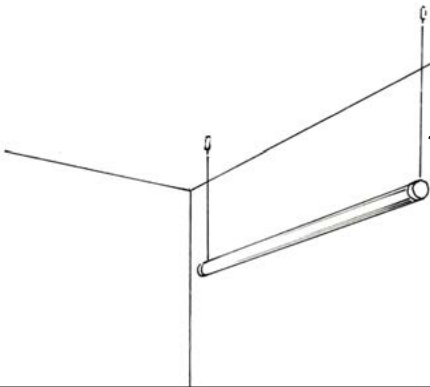

4.1

Kapitel 4 Pendel vertikal - Betondecke
Chapter 4 Vertical Pendant - Concrete ceiling

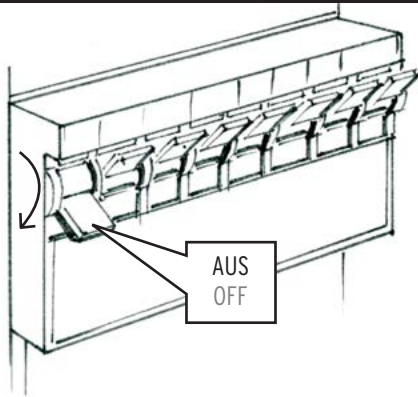

4.2

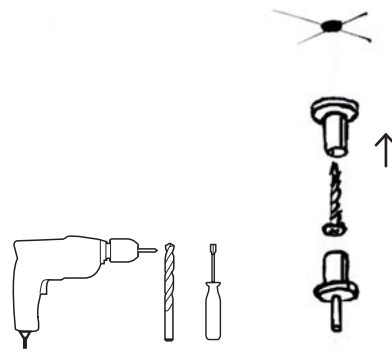

4.3

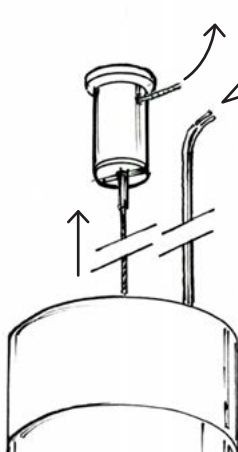

4.4

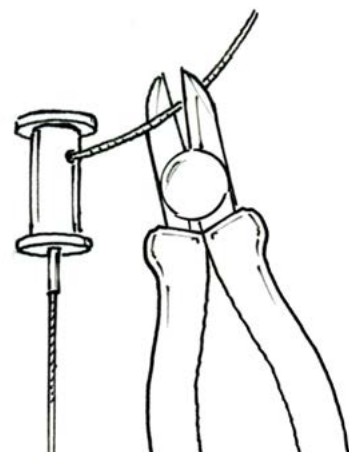

4.5

SEPARAT ERHÄLTlich
SEPARATELY AVAILABLE

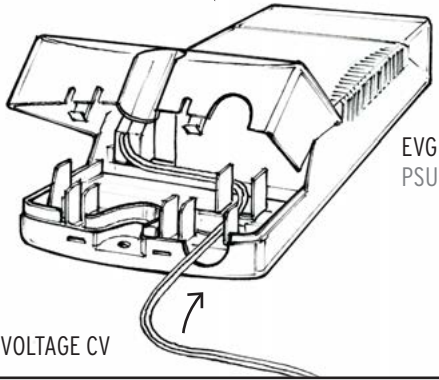

4.6

Optionales Zubehör
Optional accessories

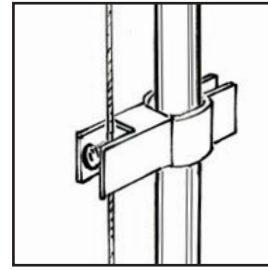

Clipmontage/Kabel: siehe Kapitel 6.1-6.6
Clip mounting/cable: see chapter 6.1-6.6

4.7

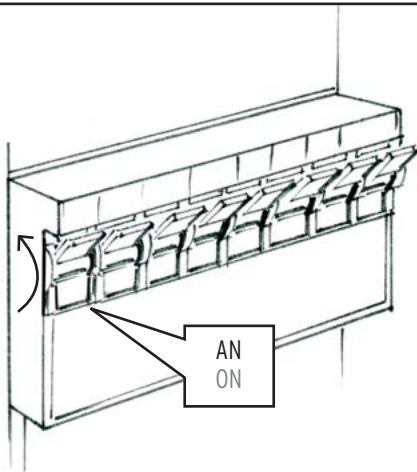

4.8

Siehe Montageanleitung
Baldachin (16000347)
See mounting instructions
of Square Canopy (16000347)

OK

Baldachin ist nicht Bestandteil des Lieferumfangs
Canopy is not part of the scope of delivery

5.1

Kapitel 5 Pendel vertikal - Abgehängte Decke
Chapter 5 Vertical Pendant - False ceiling

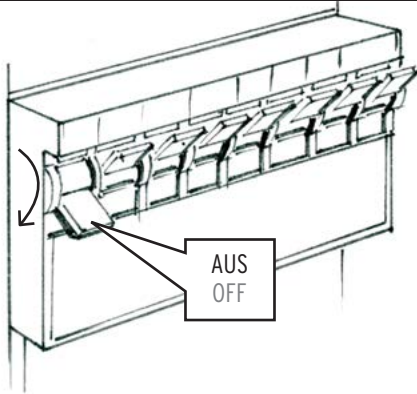

5.2

Bohrloch für Kabel
Drill hole for cable

Min. 15 mm
Min. 0,59"

Ø 12

5.3

Empfohlenes Zubehör
Recommended accessories
Innendurchmesser 12 mm
Inner diameter 12 mm

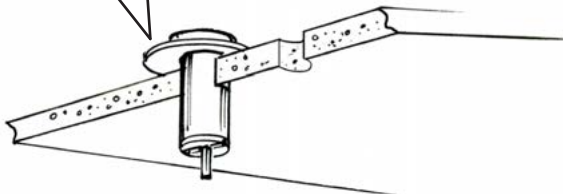
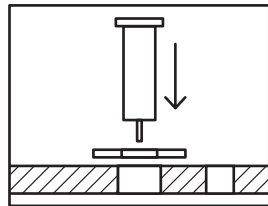

5.4

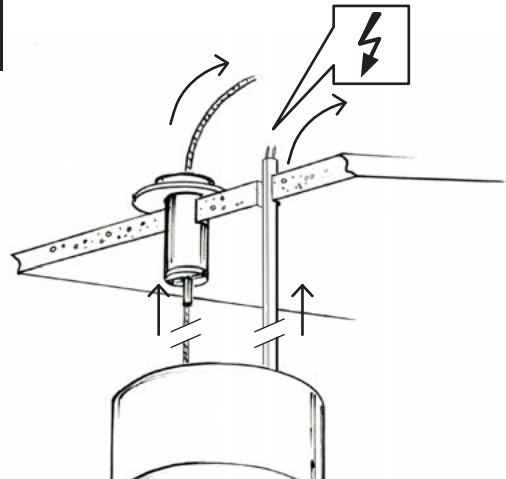

5.5

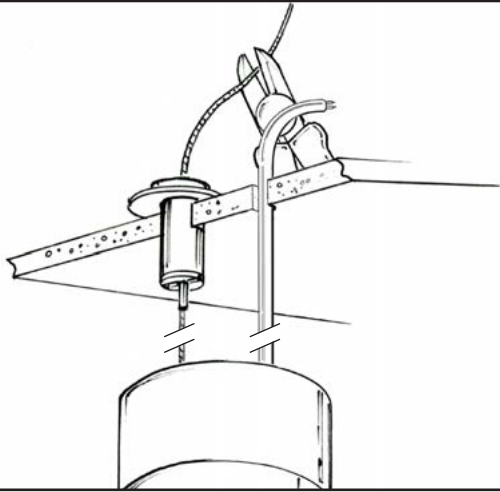

5.6

Optionales Zubehör
Optional accessories

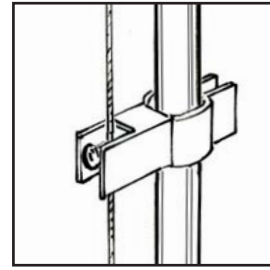

Clipmontage/Kabel: siehe Kapitel 6.1-6.6
Clip mounting/cable: see chapter 6.1-6.6

5.7

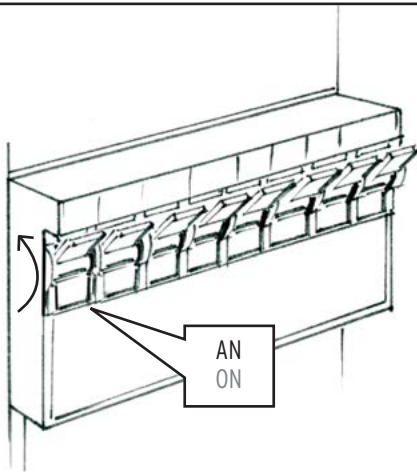

5.8

OK

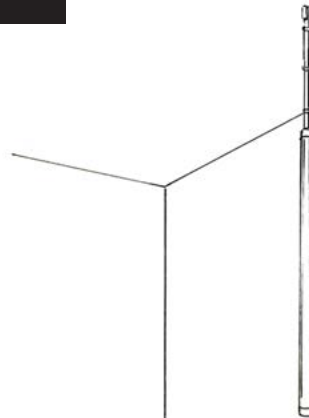

6.1

Kapitel 6 Clipmontage/Kabel
Chapter 6 Clip mounting/cable

Set beinhaltet 6 Clips
Set contains 6 clips

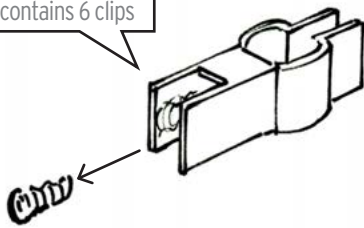

6.2

L = 50 mm
L = approx. 1,9"

L = 50 mm
L = approx. 1,9"

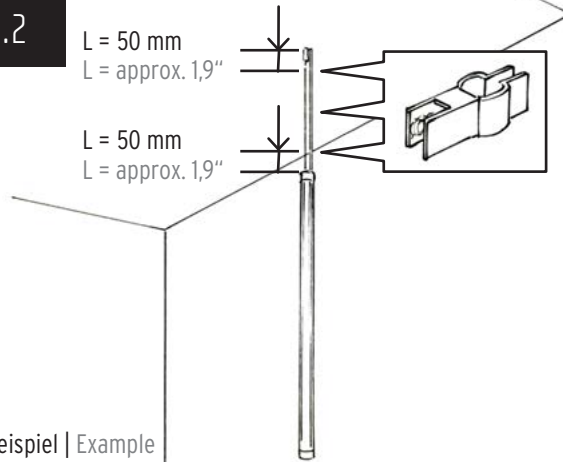

Beispiel | Example

6.3

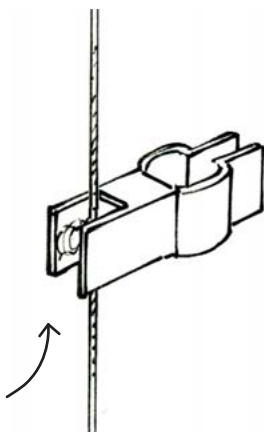

6.4

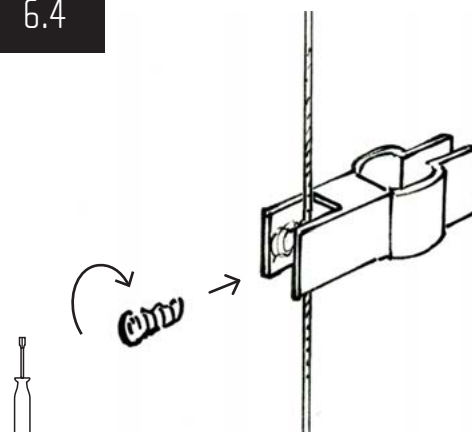

6.5

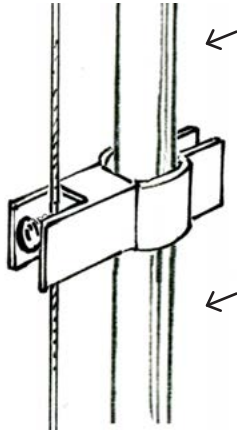

6.6

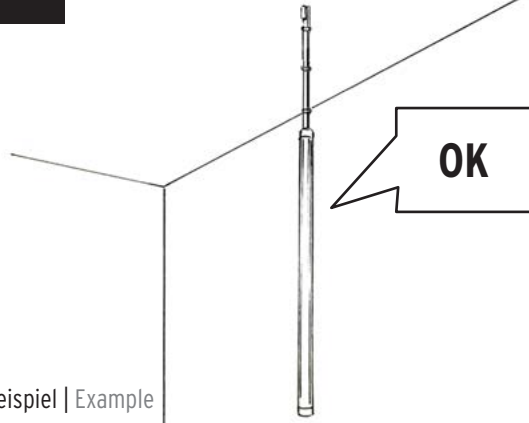

7.1

Kapitel 7 Wandmontage Trockenbauwand
Chapter 7 Wall mount drywall

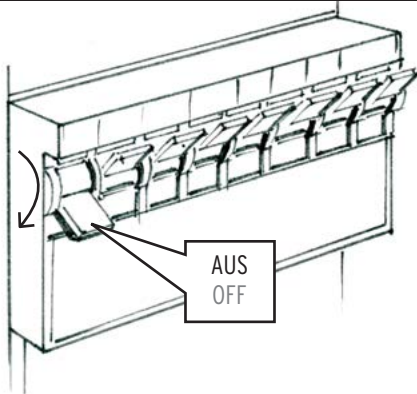

7.2

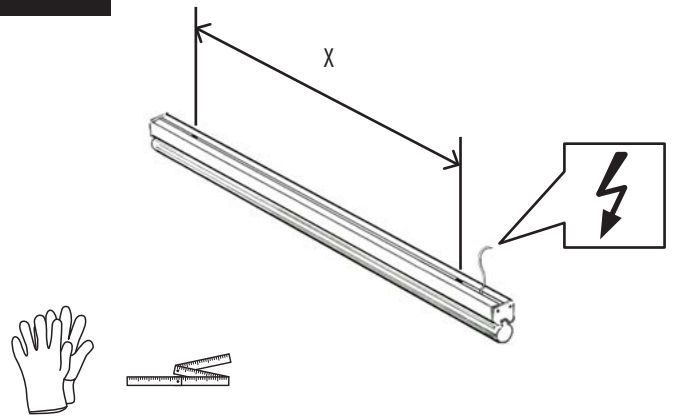

7.3

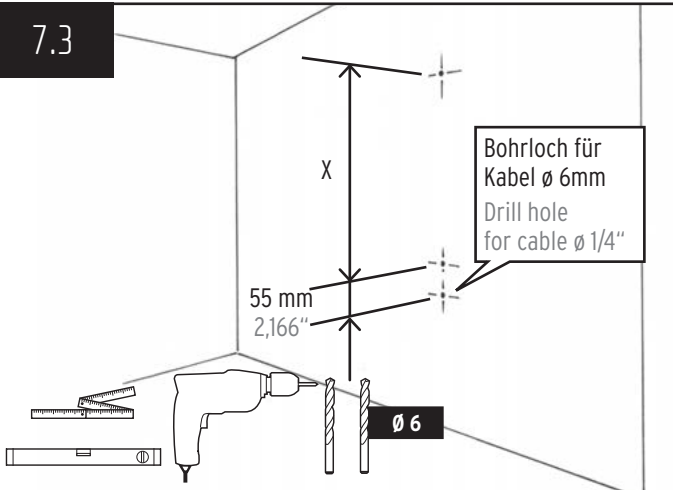

7.4

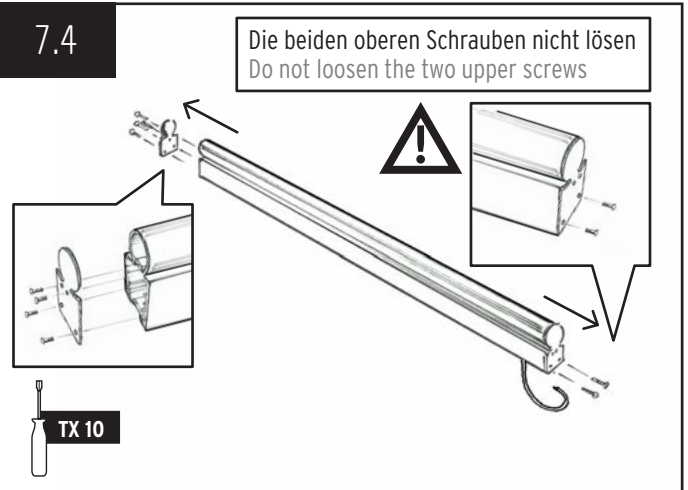

7.5

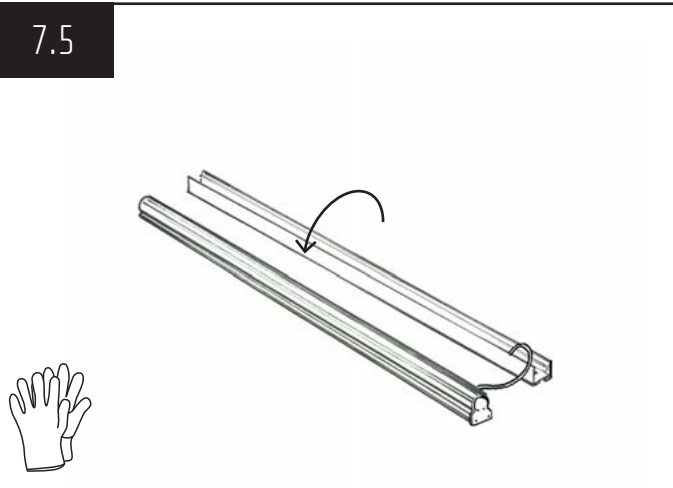

7.6

